

REV.	DESCRIPTION	DATE	BY

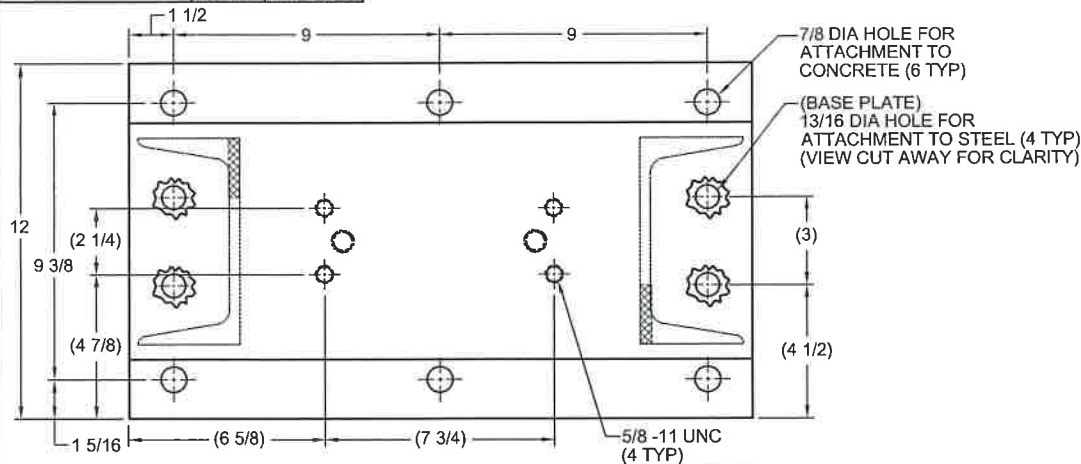

MODEL M2S-3E SEISMICALLY RESTRAINED VIBRATION ISOLATOR FOR 3" DEFLECTION

MODEL	MAX LOAD (LBS)	DEFLECTION (IN)	SPRING RATE (LB/IN)	SPRING COLOR CODE
M2S-3E-3200	3200	3.00	1066	DK. GRAY
M2S-3E-4220	4220	2.53	1666	DK. YELLOW
M2S-3E-4880	4880	2.44	2000	RED
M2S-3E-7000	7000	2.63	2666	GREEN

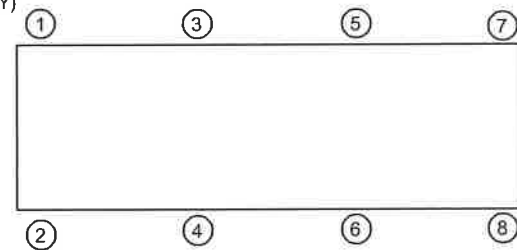
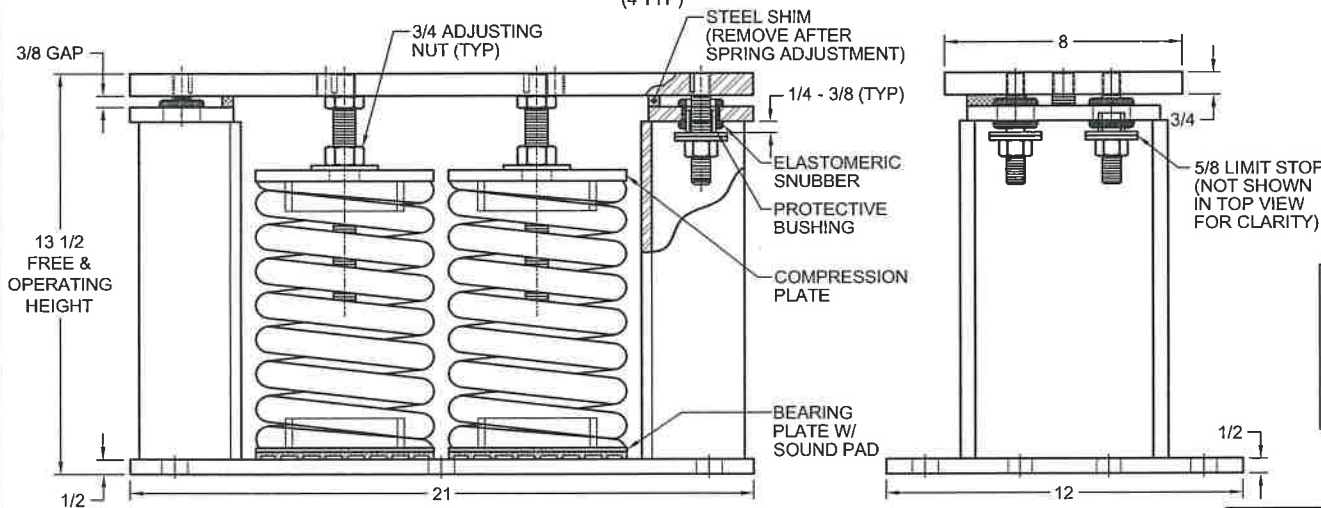

- NOTES:
1. ALL DIMENSIONS ARE IN INCHES, INTERPRET PER ANSI Y14.
 2. STANDARD FINISH: HOUSING - POWDER COAT OR PAINTED (COLOR:BLACK), SPRING - POWDER COAT OR PAINTED (FOR COLOR: SEE TABLE), HARDWARE - ELECTRO-ZINC PLATED.
 3. EQUIPMENT MUST BE BOLTED OR WELDED TO THE TOP PLATE TO MEET ALLOWABLE SEISMIC RATINGS AS REQUIRED.
 4. ISOLATOR BASE PLATE MUST BE ANCHORED TO CONCRETE WITH (6) 3/4 DIA ANCHORS OR TO STEEL WITH (4) 3/4 DIA BOLTS.
 5. ALL SPRINGS ARE DESIGNED WITH 50% OVERLOAD CAPACITY.
 6. REFER TO SHEET 2 OF 2 FOR INSTALLATION INSTRUCTIONS.
 7. RATED DEFLECTIONS ARE WITHIN 25% OF NOMINAL. HIGHER DEFLECTIONS ARE ALLOWED IF THEY MEET SPECIFICATIONS.

ISOLATOR SELECTIONS

LOC 1:	LOC 2:
LOC 3:	LOC 4:
LOC 5:	LOC 6:
LOC 7:	LOC 8:
CUSTOMER EQP'T. TAG:	

NOTE: MATERIAL SHOWN IS FOR (1) SET.
 OTHER MATERIALS, COMPOUNDS, OR FINISHES WITH EQUAL OR SUPERIOR PROPERTIES MAY BE SUBSTITUTED AS THEY BECOME AVAILABLE.



CERTIFIED FOR:

JOB NAME: _____

CUSTOMER: _____

CUSTOMER P.O.: _____

SALES ORDER: _____

**MODEL M2S-3E 3200-7000 LBS.
 VIBRATION ISOLATOR WITH
 INTEGRAL SEISMIC RESTRAINT
 AND INTERNAL ADJUSTMENT
 3 INCH DEFLECTION**



SCALE: NONE

SHEET: 1 OF 2

DRAWING NO.: _____

REVISION: _____

Member **VISCMA**

REV.	DESCRIPTION	DATE	BY

1. READ INSTRUCTIONS IN THEIR ENTIRETY BEFORE BEGINNING INSTALLATION.
2. ISOLATORS ARE SHIPPED FULLY ASSEMBLED AND ARE TO BE POSITIONED IN ACCORDANCE WITH THE SUBMITTAL DRAWINGS OR AS OTHERWISE RECOMMENDED.
3. SET ISOLATORS ON FLOOR, HOUSEKEEPING PAD, OR SUB-BASE, ENSURING THAT ALL ISOLATOR CENTERLINES MATCH THE EQUIPMENT MOUNTING HOLES. THE VMC GROUP RECOMMENDS THAT THE ISOLATOR BASE PLATES ("B") BE INSTALLED ON A LEVEL SURFACE. SHIM OR GROUT AS REQUIRED, LEVELING ALL ISOLATOR BASE PLATES AT THE SAME ELEVATION (1/4-INCH MAXIMUM DIFFERENCE CAN BE TOLERATED).
4. MARK ANCHOR HOLE LOCATIONS AS INDICATED ON BASE PLATE FOOTPRINT AND SET ISOLATOR ASIDE PRIOR TO DRILLING.
5. ANCHOR ALL ISOLATORS TO THE FLOOR, HOUSEKEEPING PAD, OR SUB-BASE USING MARKED HOLE LOCATIONS ("C") FOR CONCRETE OR ("D") FOR STEEL AS REQUIRED. USE ANCHORS MEETING THE DESIGN REQUIREMENTS SPECIFIED ON SHEET 1 OF 2. WELDING TO STEEL IS PERMITTED PROVIDING THE WELD ACHIEVES THE STRENGTH THAT IS REQUIRED TO SECURE MOUNT PER APPLIED LOADS.
6. ISOLATORS ARE SHIPPED TO THE JOBSITE WITH REMOVABLE SPACER SHIMS ("E") BETWEEN THE TOP PLATE AND THE BOTTOM HOUSING. THESE SHIMS MUST BE IN PLACE WHEN THE EQUIPMENT IS POSITIONED ON TOP OF THE ISOLATORS.

7. PLACE THE MACHINE OR EQUIPMENT ONTO TOP PLATE ("A") OF THE ISOLATORS. BOLT EQUIPMENT SECURELY TO THE ISOLATORS USING MINIMUM (2) ASTM A325 OR SAE GR. 5 HIGH-STRENGTH BOLTS (BY OTHERS). WELDING IS PERMITTED PROVIDING THE WELD ACHIEVES THE REQUIRED STRENGTH.
8. THE ADJUSTMENT PROCESS CAN ONLY BEGIN AFTER THE EQUIPMENT OR MACHINE IS AT ITS FULL OPERATING WEIGHT.
9. BACK OFF EACH OF THE LIMIT STOP LOCKNUTS ("F") 1/4- TO 3/8-INCH FROM THEIR AS-SHIPPED POSITION.
10. ADJUST EACH ISOLATOR IN SEQUENCE BY TURNING ADJUSTING NUT(S) ("G") ONE FULL CLOCKWISE TURN AT A TIME. REPEAT THIS PROCEDURE ON ALL ISOLATORS, ONE AT A TIME. CHECK THE LIMIT STOP LOCKNUTS ("F") PERIODICALLY TO ENSURE THAT CLEARANCE BETWEEN THE WASHER AND RUBBER GROMMET IS MAINTAINED. STOP ADJUSTMENT OF AN ISOLATOR ONLY WHEN THE TOP PLATE ("A") HAS RISEN JUST ABOVE THE SHIM ("E").
11. REMOVE ALL SPACER SHIMS ("E").
12. FINE ADJUST ISOLATORS TO LEVEL EQUIPMENT.
13. ADJUST ALL LIMIT STOP LOCKNUTS ("F") BACK UP TO OBTAIN 3/8-INCH GAP AS SHOWN. THE LIMIT STOP NUTS MUST BE KEPT AT THIS 3/8-INCH GAP TO ENSURE UNIFORM BOLT LOADING DURING UPLIFT (AS IN THE CASE WHEN A COOLING TOWER IS DRAINED).
14. INSTALLATION IS COMPLETE.

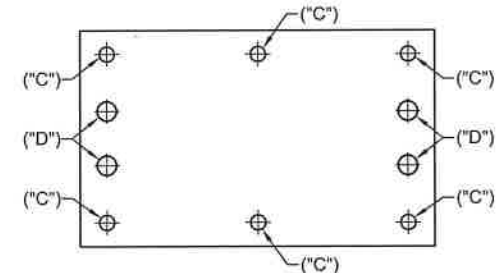
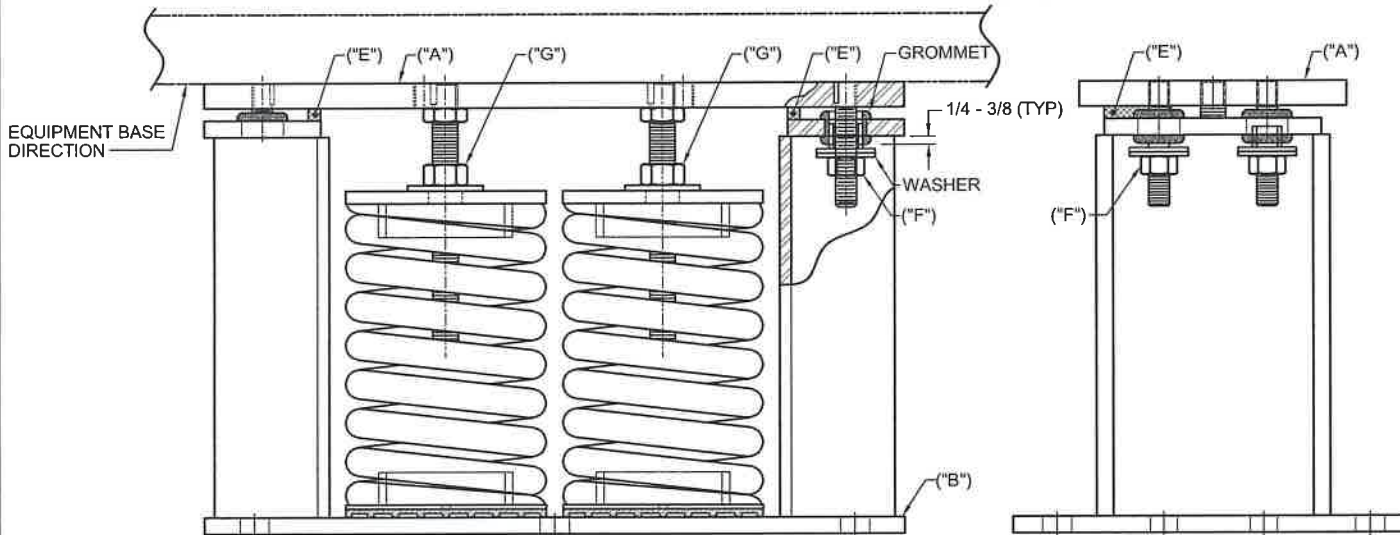

BASE PLATE HOLE LOCATION DIAGRAM
 NOTE: ISOLATOR BASE PLATE IS TO BE USED FOR HOLE LOCATION MARKING ONLY AND NOT AS A DRILLING GUIDE.

OTHER MATERIALS, COMPOUNDS, OR FINISHES WITH EQUAL OR SUPERIOR PROPERTIES MAY BE SUBSTITUTED AS THEY BECOME AVAILABLE.



CERTIFIED FOR:

JOB NAME: _____
 CUSTOMER: _____
 CUSTOMER P.O.: _____
 SALES ORDER: _____

**MODEL M2S-3E 3200-7000 LBS.
 VIBRATION ISOLATOR WITH
 INTEGRAL SEISMIC RESTRAINT
 AND INTERNAL ADJUSTMENT
 3 INCH DEFLECTION**



SCALE: NONE	Member VISCMA
SHEET: 2 OF 2	
DRAWING NO.:	REVISION